

Standard executions		
Version	Symbol	Type
Standard		S1
Short (for light loads)		S2



Options		Suffix
Both connections on one head	from bore 25 mm.	U
Carriage with integral brake	(see page 1.26.35)	B
Special versions on request		/ S

Rodless cylinders, magnetic as standard.

Cylinders with direct power transmission through the tube slot onto the yoke. The new cushionings are adjustable at both ends; the flow rate is regulated from 0 to 100% by turning a pin of an angle of 90°. The new barrel with high resistance to deflection is provided with grooves for fixing various accessories.

The magnetic switches can be fixed by a bracket or directly in the tube; the reed switch will not protrude out the barrel profile.

The short cylinder type S2, in comparison to the standard cylinder - 0 - stroke, is up to 42% shorter; the total fitting length is therefore reduced and the cylinder is more compact and money-saving.

For the magnetic reed switches ASV-ASC see page 1.26.40.  
For mounting accessories see from page 1.26.28.

The options can be combined (when this is possible).

For parameters of the loads and moments see from page 1.26.25.  
For seal kits see from page 1.26.21.

How to order: 32 / 1000 S1U

32	/	1000	S1	U
Bore	/	Stroke	Type	Option

Technical data	
Fluid	Compressed filtered air with or without lubrication. Lubrication, if started, must be continued.
Pressure	2 ÷ 8 bar
Temperature range	-20 °C + + 80°C
Materials	Heads: Anodised aluminium Tube: Anodised aluminium Seals: Polyurethane - Piston: monobloc/yoke: Aluminium Internal strip: Nylon External strip: Stainless steel AISI 304 Raschiapolvere: PVC

Bore (mm)	Standard strokes (mm)	Max stroke (mm)	Cushion length (mm)	Theoretical force at 6 bar (N)	Weight at 0 stroke Type S1 (g)	Weight at 0 stroke Type S2 (g)	Weight for every 10 mm stroke (g)
18	from 10 to 6000	9000	15	140	300	200	15
25			18	270	600	400	26
32			24	440	1100	700	36
40			34	680	1800	1200	48
50			40	1060	3200	2000	74
63			49	1680	5600	3200	101

Standard executions		
Version	Symbol	Type
Guided		S3
Short guided (for light loads)		S5
Double guide		S6



Options	Suffix
Both connections on one head	from bore 25 mm. U
Special versions on request	/ S

The options can be combined (when this is possible).

For parameters of the loads and moments see from page 1.26.25.

For seal kits see from page 1.26.21.

Rodless cylinders, magnetic as standard.

Cylinders with direct power transmission through the tube slot onto the yoke. The new cushionings are adjustable at both ends; the flow rate is regulated from 0 to 100% by turning a pin of an angle of 90°. The new barrel is provided with grooves for fixing various accessories. The magnetic switches can be fixed by a bracket or directly in the tube; the reed switch will not protrude out the barrel profile. The side carriage (which can also be installed at a later date) is adjustable and this allows to use the cylinder with heavier loads; the guide moves by Teflon slides, fixed in the grooves of the tube. The short guided cylinders type S5, in comparison to the standard cylinder - 0 - stroke, is up to 42% shorter; the total fitting length is therefore reduced and the cylinder is more compact and money-saving.

For the magnetic reed switches ASV-ASC see page 1.26.40.  
For mounting accessories see from page 1.26.28.

How to order: 50 / 1000 S6U

50	/	1000	S6	U
Bore	/	Stroke	Type	Option

Technical data	
Fluid	Compressed filtered air with or without lubrication. Lubrication, if started, must be continued.
Pressure	2 ÷ 8 bar
Temperature range	-20 °C ÷ + 80°C
Materials	Heads: Anodised aluminium Tube: Anodised aluminium Seals: Polyurethane - Piston: monobloc/yoke: Aluminium Internal strip: Nylon External strip: Stainless steel AISI 304 Wiper ring: PVC Carriage: Aluminium

Bore (mm)	Standard strokes (mm)	Max stroke (mm)	Cushion length (mm)	Theoretical force at 6 bar (N)	Weight at 0 stroke Type S3 (g)	Weight at 0 stroke Type S5 (g)	Weight at 0 stroke Type S6 (g)	Weight for every 10 mm stroke (g)
18	from 10 to 6000	9000	15	140	400	250	500	15
25			18	270	900	550	1200	26
32			24	440	1500	1100	1900	36
40			34	680	2800	1700	3800	48
50			40	1060	4900	2850	6600	74
63			49	1680	8000	4400	10400	101

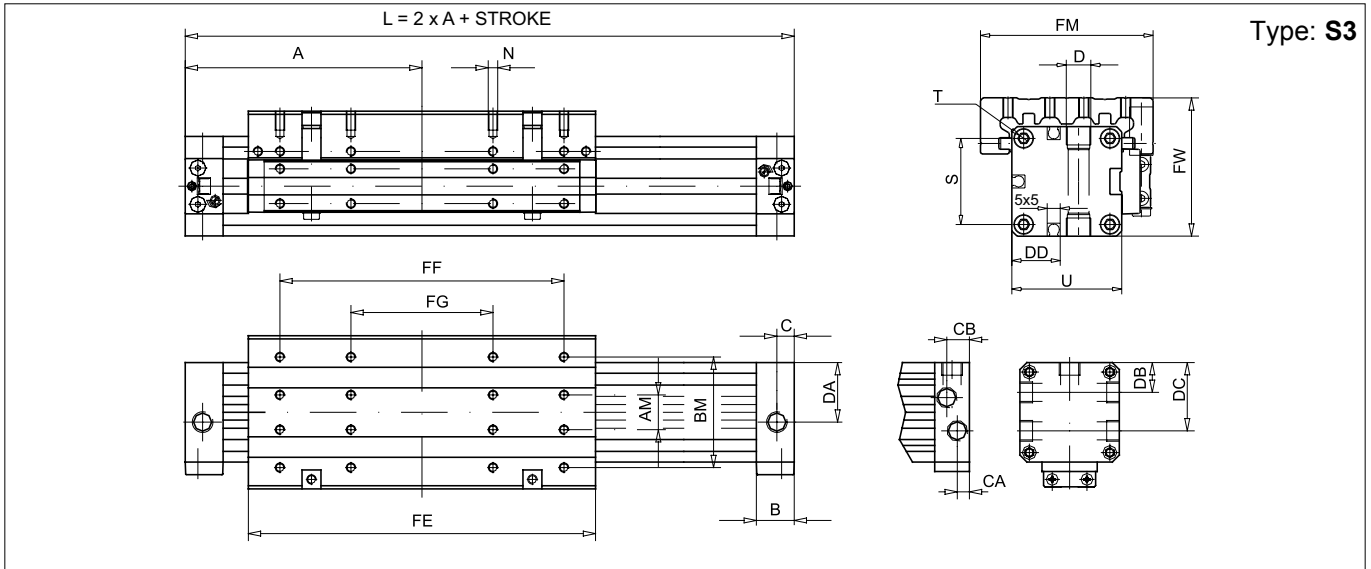

Type: **S3**

Ø mm	A	AM	B	BM	C	CA	CB	D	DA	DB	DC	DD	FE	FF	FG	FM	FW	N	□ S	T	□ U
18	80	10	16,5	35	6,5	-	-	M7x1/6	17,5	-	-	-	103	75	-	50	39	M4x7,5	23,5	M3x7	30
25	100	13	20	45	8,5	7	13	G1/8x8	25,5	14	28	18,5	131	100	50	66	53	M4x8	33	M4x9	42
32	120	16	20	55	8,5	7	13	G1/8x8	32	17,5	34,5	21	171	140	70	80	65	M5x10	41	M5x10	52
40	150	22	24	70	13	9,5	14,5	G1/4x12	37,5	20	42	29,5	220	180	90	97	79	M6x12	51	M6x12	63
50	180	29	24	85	13	9,5	14,5	G1/4x12	47,5	26	52	37	280	220	110	116	96	M8x16	63	M8x12	78
63	215	40	30	105	13	11	18,5	G3/8x12	59,5	30	62	44,5	333	280	140	136	113,5	M8x16	78	M8x12	93

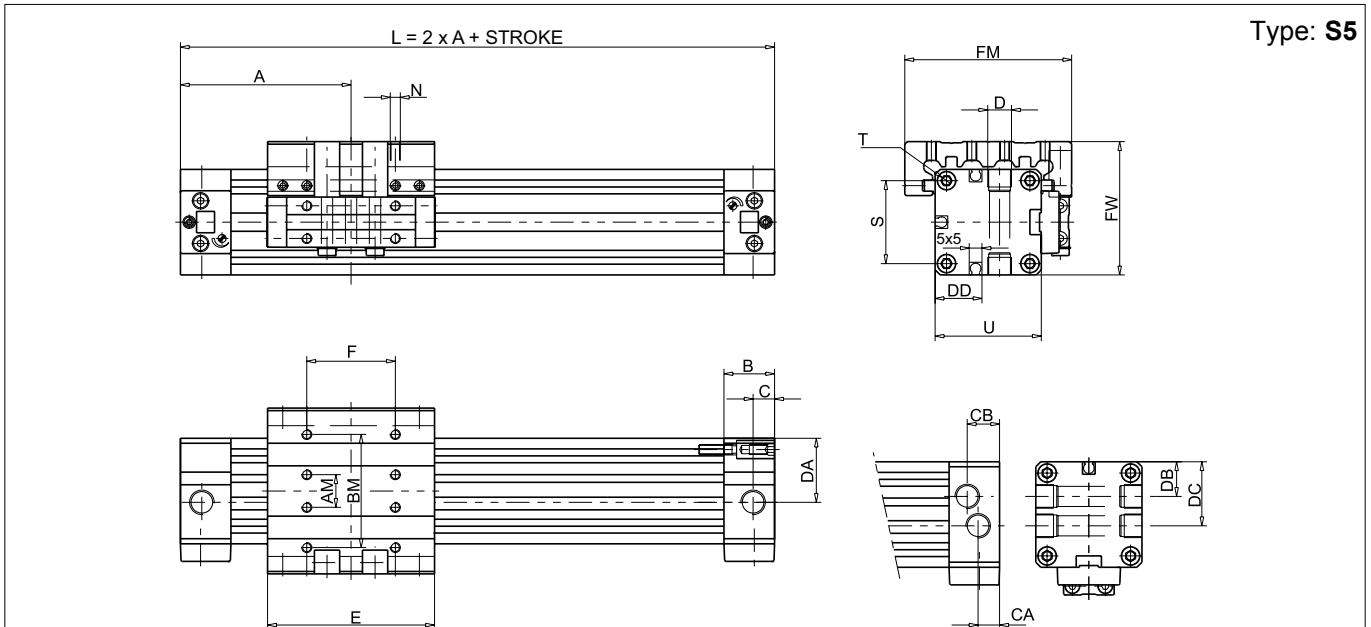

Type: **S5**

Ø mm	A	AM	B	BM	C	CA	CB	D	DA	DB	DC	DD	E	F	FM	FW	N	□ S	T	□ U
18	57,5	10	16,5	35	6,5	-	-	M7x1/6	17,5	-	-	15	58	30	50	39	M4x7,5	23,5	M3x7	30
25	67,5	13	20	45	8,5	7	13	G1/8x8	25,5	14	28	21	66	35	66	53	M4x8	33	M4x9	42
32	77,5	16	20	55	8,5	7	13	G1/8x8	32	17,5	34,5	26	86	55	80	65	M5x10	41	M5x10	52
40	95	22	24	70	13	9,5	14,5	G1/4x12	37,5	20	42	31,5	110	70	97	79	M6x12	51	M6x12	63
50	105	29	24	85	13	9,5	14,5	G1/4x12	47,5	26	52	39	130	70	116	96	M8x16	63	M8x12	78
63	125	40	30	105	13	11	18,5	G3/8x12,5	59,5	30	62	46,5	153	100	136	113,5	M8x16	78	M8x12	93

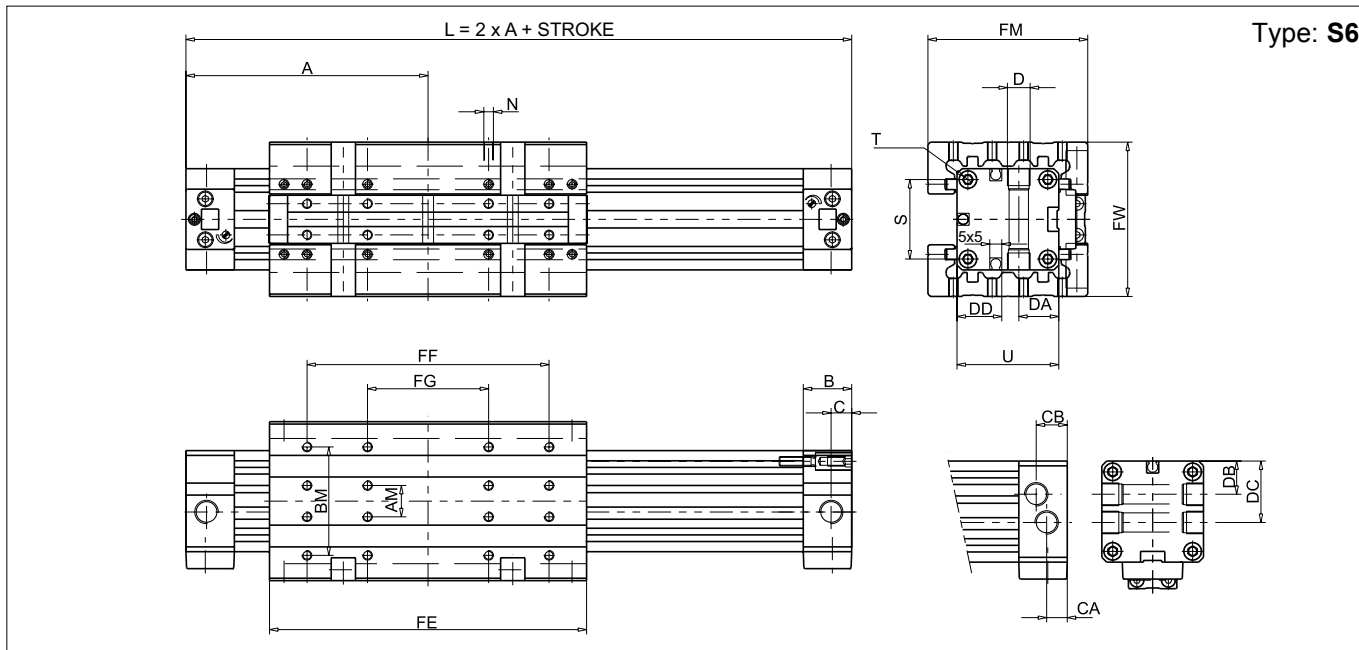

Ø mm	A	AM	B	BM	C	CA	CB	D	DA	DB	DC	DD	FE	FF	FG	FM	FW	N	□ S	T	□ U
18	80	10	16,5	35	6,5	-	-	M7x1/6	17,5	-	-	-	103	75	--	50	48	M4x7,5	23,5	M3x7	30
25	100	13	20	45	8,5	7	13	G1/8x8	25,5	14	28	18,5	131	100	50	66	64	M4x8	33	M4x9	42
32	120	16	20	55	8,5	7	13	G1/8x8	32	17,5	34,5	21	171	140	70	80	78	M5x10	41	M5x10	52
40	150	22	24	70	13	9,5	14,5	G1/4x12	37,5	20	42	29,5	220	180	90	97	95	M6x12	51	M6x12	63
50	180	29	24	85	13	9,5	14,5	G1/4x12	47,5	26	52	37	280	220	110	116	114	M8x16	63	M8x12	78
63	215	40	30	105	13	11	18,5	G3/8x12	59,5	30	62	44,5	333	280	140	136	134	M8x16	78	M8x12	93

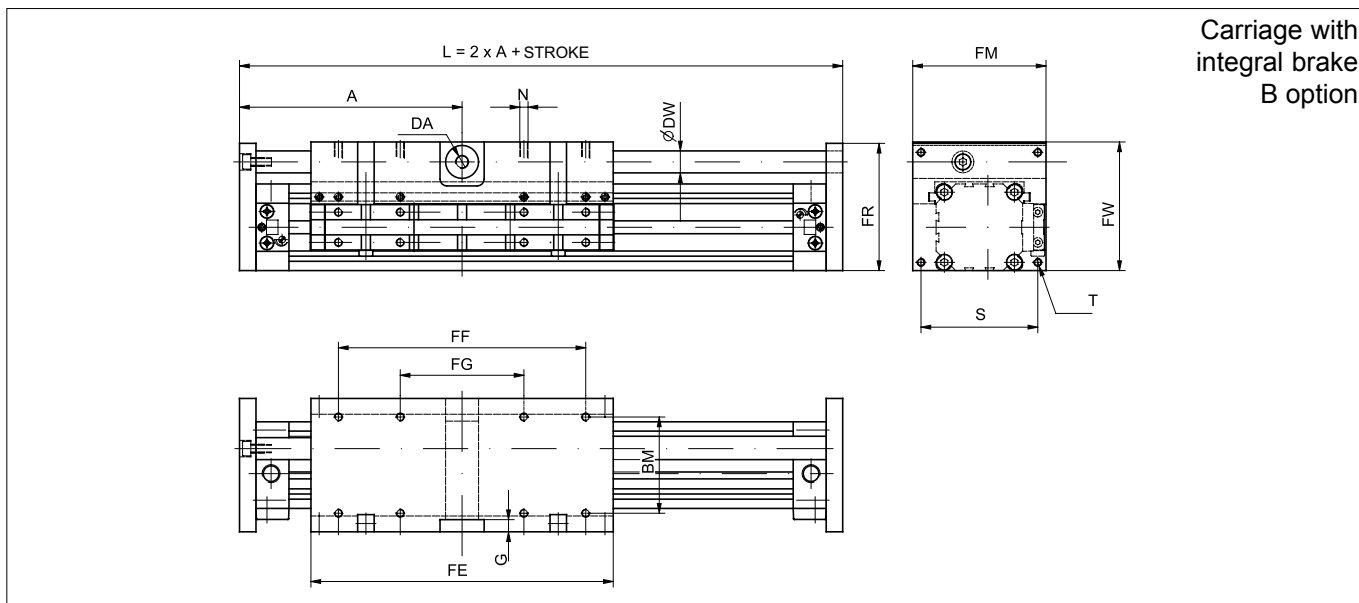

Should it be necessary to lock a working or a handling, the carriage with integral brake can be used.  
 Materials: carriage: Aluminium; rod: Hardened and chrome plated steel.

Ø mm	A	BM	D	DA	DW	FE	FF	FG	FM	FW	FR	G	N	S	T	U	Fb
18	86	35	M5-5,5	M5	Ø 6	103	75	-	50	48	47	6	M4-7,5	42	M3	6	180N
25	110	45	1/8"-7,7	M5	Ø 12	131	100	50	66	67	66	-	M4-8	54	M4	10	600N
32	130	55	1/8"-7,7	M5	Ø 12	171	140	70	80	79	78	5	M5-10	68	M5	10	600N
40	162	70	1/4"-11,7	1/8"	Ø 16	220	180	90	97	93,5	92,5	-	M5-12	80	M6	12	1000N
50	195	85	1/4"-11,7	1/8"	Ø 20	280	220	110	116	11,5	114,5	-	M8-16	100	M8	15	1400N
63	230	105	3/8"-11,7	1/8"	Ø 25	333	280	140	136	139	138	-	M8-16	120	M8	15	2500N

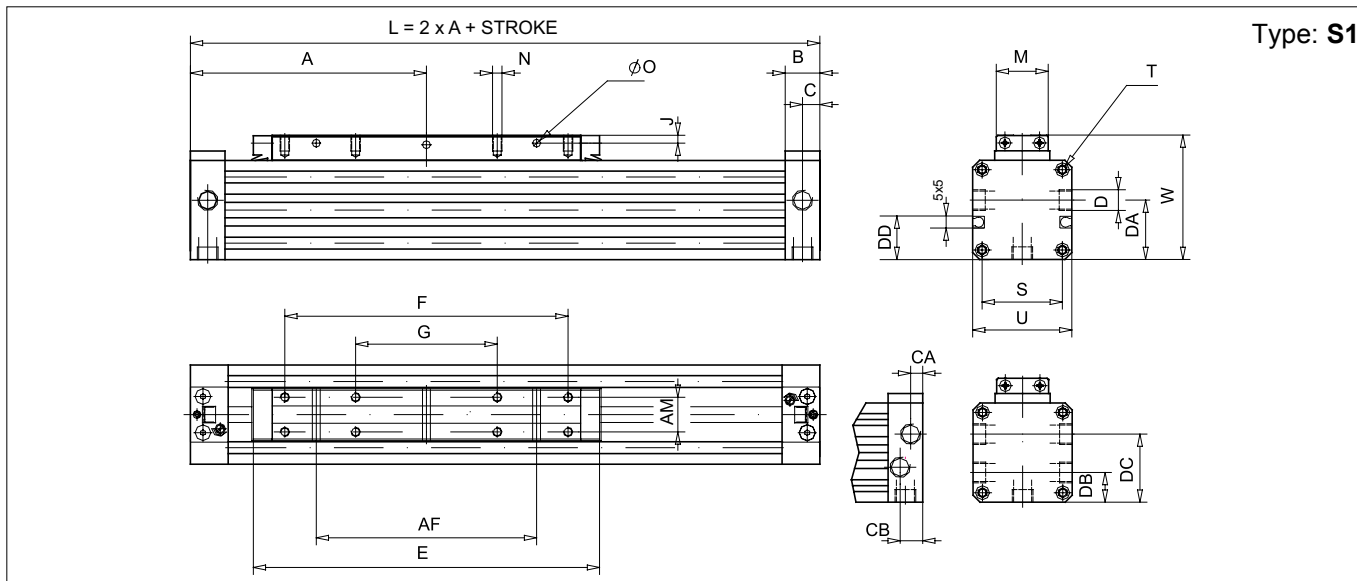

Type: **S1**

Ø mm	A	AF	AM	B	C	CA	CB	D	DA	DB	DC	DD	E	F	FE	G	J	M	N	Ø O	□ S	T	□ U	W
18	80	50	10	16,5	6,5	-	-	M7x1/6	15,5	-	-	-	103	75	90	-	3	15,5	M3x6	3,5	23,5	M3x7	D 30	39
25	100	70	13	20	8,5	7	13	G1/8x8	25,5	14	28	18,5	131	100	116	50	3,5	20	M4x7	4,5	33	M4x9	D 42	53
32	120	100	16	20	8,5	7	13	G1/8x8	32	16	34,5	21	171	140	156	70	4,5	25	M5x9	5,5	41	M5x10	D 52	65
40	150	140	22	23	13	11	14,5	G1/4x12	37,5	18,5	41	29,5	220	180	200	90	5	33	M6x10	7	51	M6x12	D 63	79
50	180	180	29	23	13	12	14	G1/4x12	47,5	22,5	47,5	37	280	220	260	110	6,5	42	M8x12,5	7	63	M8x12	D 78	96
63	215	230	40	29	13	12,5	15,5	G3/8x12	59,5	24,5	59,5	44,5	333	280	313	140	8	54	M8 x 15	9	D 78	M8x12	D 93	113,5

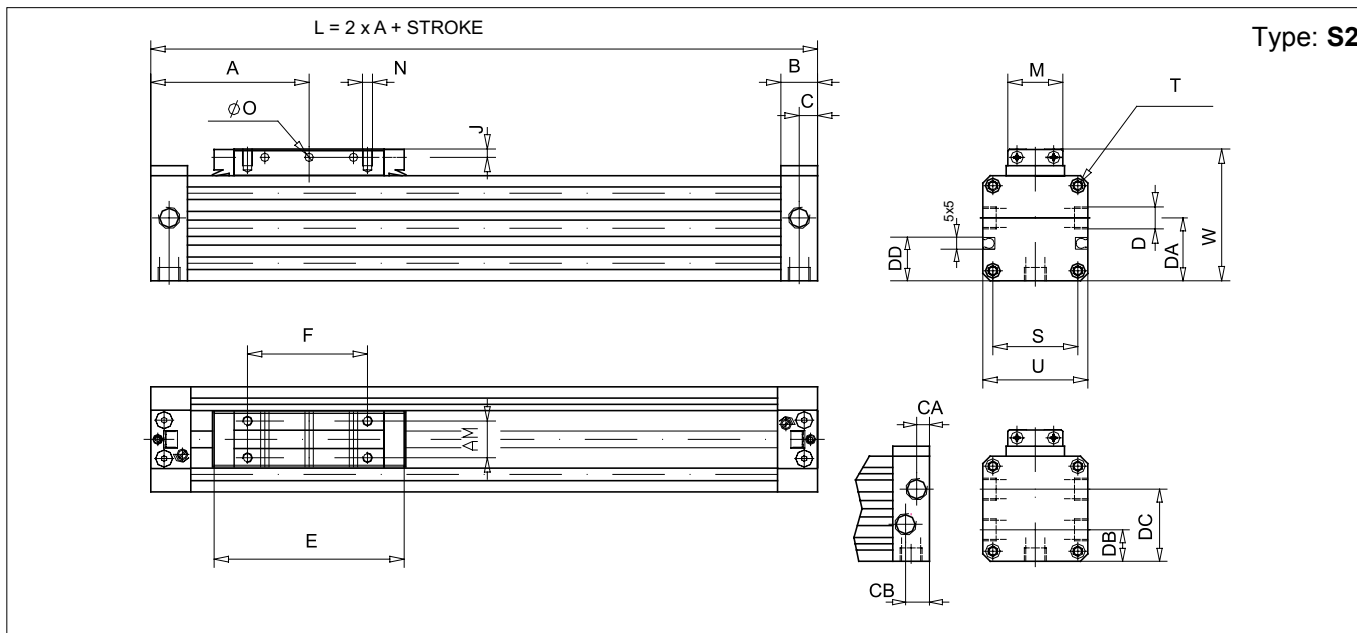

Type: **S2**

Ø mm	A	AF	AM	B	C	CA	CB	D	DA	DB	DC	DD	E	F	FE	J	M	N	Ø O	□ S	T	□ U	W
18	57,5	15	10	16,5	6,5	-	-	M7x1/6	17,5	-	-	-	58	30	45	3	15,5	M3x6	3,5	23,5	M3x7	30	39
25	67,5	19	13	20	8,5	7	13	G1/8x8	25,5	14	28	18,5	66	35	51	3,5	20	M4x7	4,5	33	M4x9	42	53
32	77,5	35	16	20	8,5	7	13	G1/8x8	32	17,5	34,5	21	86	55	71	4,5	25	M5x9	5,5	41	M5x10	52	65
40	95	50	22	23	13	9,5	14,5	G1/4x12	37,5	20	42	29,5	110	70	90	5	33	M6x10	7	51	M6x12	63	79
50	105	46	29	23	13	9,5	14,5	G1/4x12	47,5	26	52	37	130	70	110	6,5	42	M8x12,5	7	63	M8x12	78	96
63	125	70	40	29	13	11	18,5	G3/8x12,5	59,5	30	62	44,5	153	100	133	8	54	M8x15	9	78	M8x12	93	113,5

Standard executions			
Version		Symbol	Type
Parallel	from bore 25 mm.		S4



Options	Suffix
Special versions on request	/ S

For parameters of the loads and moments see from page 1.26.25.  
For seal kits see from page 1.26.21.

Rodless cylinders, standard in the magnetic version. Cylinders with direct power transmission through the tube slot onto the yoke. The new cushionings are adjustable at both ends; the flow rate is regulated from 0 to 100% by turning a pin of an angle of 90°. The new barrel is provided with grooves for fixing various accessories. The magnetic switches can be fixed by a bracket or directly in the tube; the reed switch will not protrude out the barrel profile. They are fit for heavy loads and moments in every direction; they are double action force cylinders provided with central air connections. Should it be necessary, linear guides can also be applied at a later date (special application). The yokes are provided with front and side wiper strips.

For the magnetic reed switches ASV-ASC see page 1.26.40.  
For mounting accessories see from page 1.26.28.

How to order: 50 / 500 S4

50	/	500	S4	
Bore	/	Stroke	Type	Option

Technical data	
Fluid	Compressed filtered air with or without lubrication. Lubrication, if started, must be continued.
Pressure	2 ÷ 8 bar
Temperature range	-20 °C ÷ + 80°C
Materials	Heads: Anodised aluminium Tube: Anodised aluminium Seals: Polyurethane - Piston monobloc/yoke: Aluminium Internal strip: Nylon External strip: Stainless steel AISI 304 Wiper ring: PVC Coupling plate: Aluminium

Bore (mm)	Standard strokes (mm)	Max stroke (mm)	Cushion length (mm)	Theoretical force at 6 bar (N)	Weight at 0 stroke Type S4 (g)	Weight for every 10 mm stroke (g)
25	from 10 to 6000	9000	18	540	1200	52
32			24	880	2600	72
40			34	1360	4600	98
50			40	2120	8200	150
63			49	3360	13600	204

Type: S4

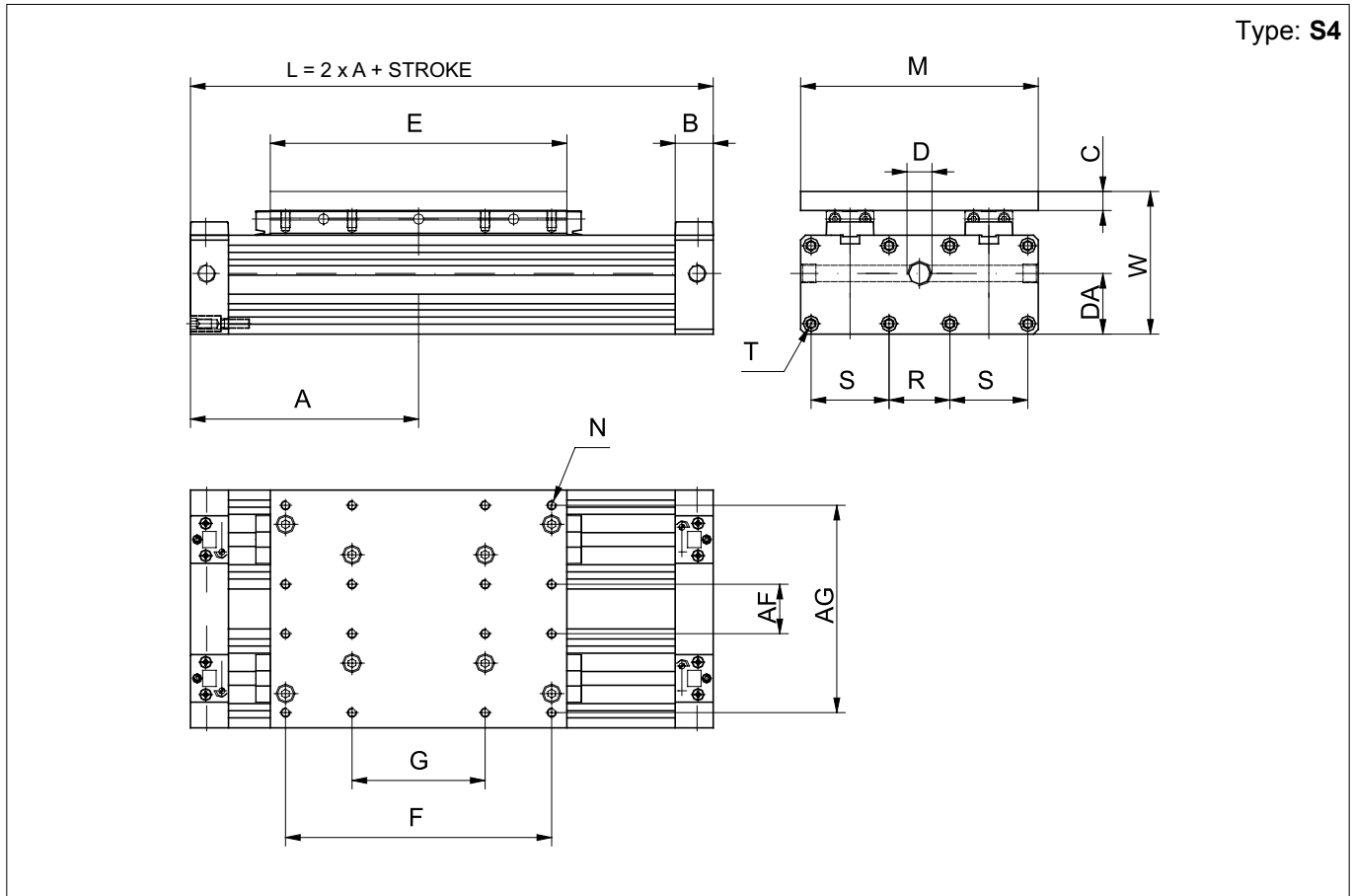

Ø mm	A	B	C	D	DA	E	F	G	AF	AG	M	N	R	S	T	W
25	100	20	8	G1/4-11,7	25,5	116	100	50	21	79	92	M4	17	33x33	M4x9	61
32	120	20	10	G1/4-11,7	40	156	140	70	26	109	125	M5	32	41x41	M5x10	75
40	150	24	12	G3/8-11,7	47	200	180	90	35	133	153	M6	45	51x51	M6x12	91
50	180	24	15	G3/8-11,7	59	260	220	110	44	164	184	M8	43	63x63	M8x12	111
63	215	30	15	G1/2-13	71	313	280	140	55	195	218	M8	47	78x78	M8x12	128,5

Seal kit.

Here are the quantities and the description of the components comprised in each kit.

Description	N°	S1	S2	S3	S4 *	S5	S6 **
Front wiper rings	2	•	•	•	•	•	•
Front wiper rings	2	•	•	•	•	•	•
Piston seals	2	•	•	•	•	•	•
Cushionings seals	2	•	•	•	•	•	•
Heads O-ring	2	•	•	•	•	•	•
Cushioning pin O-ring	2	•	•	•	•	•	•
▲ Internal strip	1	•	•	•	•	•	•
▲ External strip	1	•	•	•	•	•	•
▲ Internal seals (between the strip and the tube)	2	•	•	•	•	•	•
Teflon slides for guide	2			•		I	•

\* For the type S4 (parallel) one seal kit includes twice as many as the components are.

\*\* For the type S6 (double guide) one seal kit includes 4 Teflon slides.

How to order: 32 / 500 / SG / S4

32	/	500	/	SG	/	S4	
Bore	/	Stroke cylinder	/	Seal kit	/	Type	Option

▲ The length is according to the stroke of the cylinder.

# Rodless Cylinders

## Bores from 18 to 63 mm

### Loads and moments

All data concerning forces refer to a speed of  $V < 0,35$  m/s.

Keeping the indicated values ensures the maximum service life, the minimum noise and the best operating result.

Higher speeds reduce the admissible forces.

Were the working conditions out of the allowed limits (see table below), the energy of the mass in motion should be absorbed by devices (such as hydraulic cushionings, stops) mounted as much nearer as possible to the barycentre of the mass.

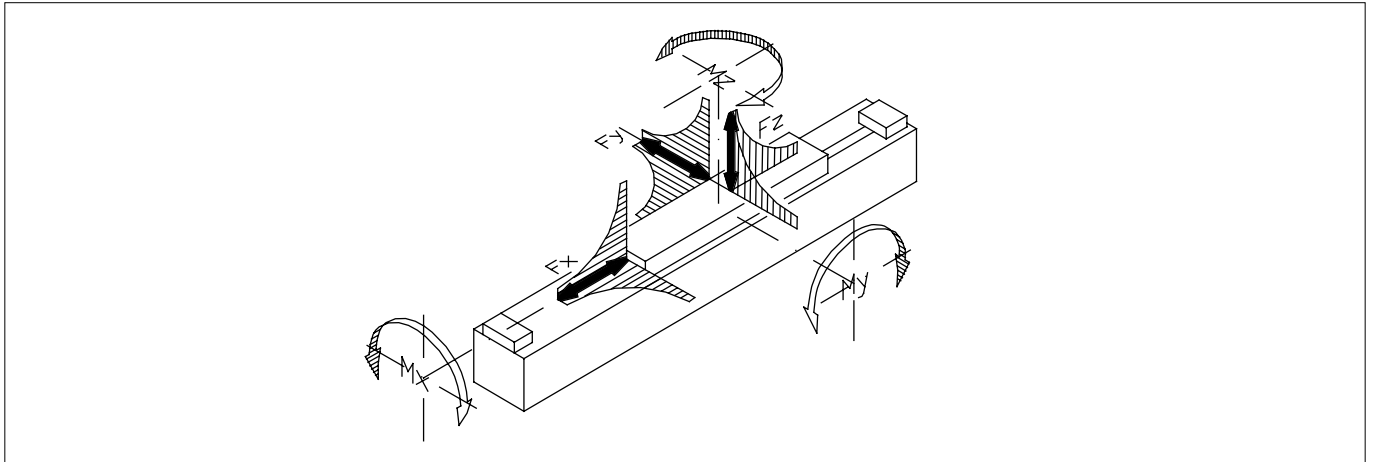

Type: **S1**

Ø mm	Force ( $V_{max} \leq 0,35$ m/s)			F (load in N)			Moments		
	Fx (N) 6 bar	Fy (N) 6 bar	Fz (N) 6 bar	at 0,75 m/s	at 1 m/s	at 1,5 m/s	Mx (Nm) Fy/Fz	My (Nm) Fx/Fz	Mz (Nm) Fx/Fy
18	140	80	300	80	40	20	1	3	3
25	270	110	480	155	90	40	2	13	13
32	440	165	650	280	155	70	3,5	25	25
40	680	225	800	500	290	125	5,5	40	40
50	1060	325	1060	790	420	195	10	65	65
63	1680	435	1680	1500	850	370	16	100	100

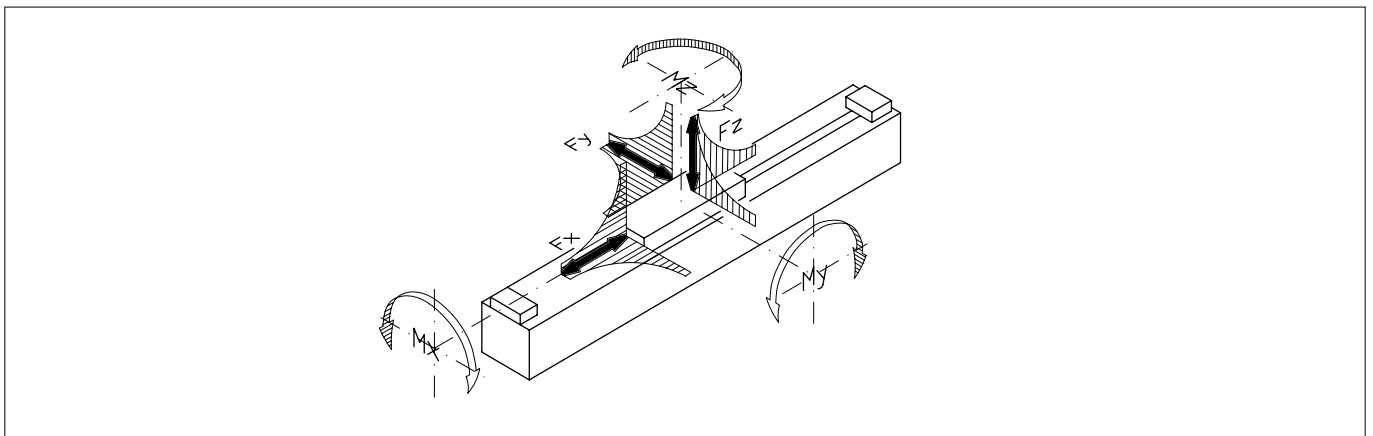

Type: **S2**

Ø mm	Force ( $V_{max} \leq 0,35$ m/s)			F (load in N)			Moments		
	Fx (N) 6 bar	Fy (N) 6 bar	Fz (N) 6 bar	at 0,75 m/s	at 1 m/s	at 1,5 m/s	Mx (Nm) Fy/Fz	My (Nm) Fx/Fz	Mz (Nm) Fx/Fy
18	140	40	140	40	25	10	0,4	1,7	1,7
25	270	55	230	90	50	25	0,7	2,7	2,7
32	440	70	320	200	110	45	1	5	5
40	680	100	400	420	240	110	2	8,5	8,5
50	1060	140	480	750	440	190	3,5	13	13
63	1680	180	590	1500	850	380	5	18	18



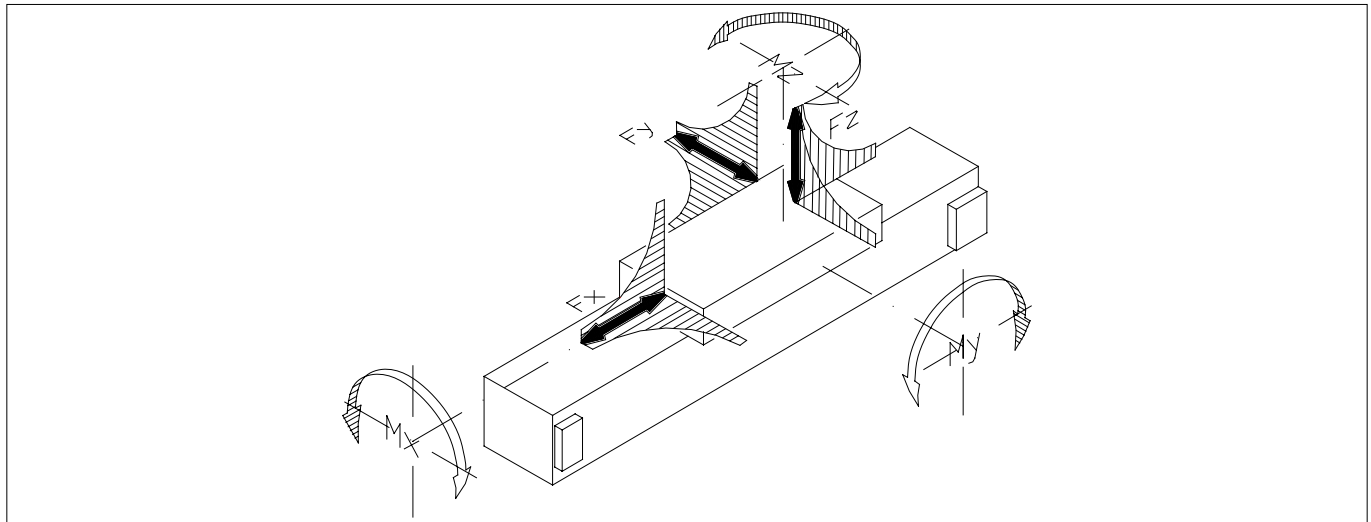

Type: **S3**

Ø mm	Force ( $V_{max} \leq 0,35 \text{ m/s}$ )			F (load in N)			Moments		
	Fx (N) 6 bar	Fy (N) 6 bar	Fz (N) 6 bar	at 0,75 m/s	at 1 m/s	at 1,5 m/s	Mx (Nm) Fy/Fz	My (Nm) Fx/Fz	Mz (Nm) Fx/Fy
18	140	370	370	100	58	26	3,5	6	6
25	270	800	800	280	160	65	10	20	20
32	440	1200	1200	510	300	140	25	45	45
40	680	1600	1600	1000	550	250	40	75	75
50	1060	2100	2100	1500	850	380	80	150	150
63	1680	2800	2800	2500	1400	610	110	250	250

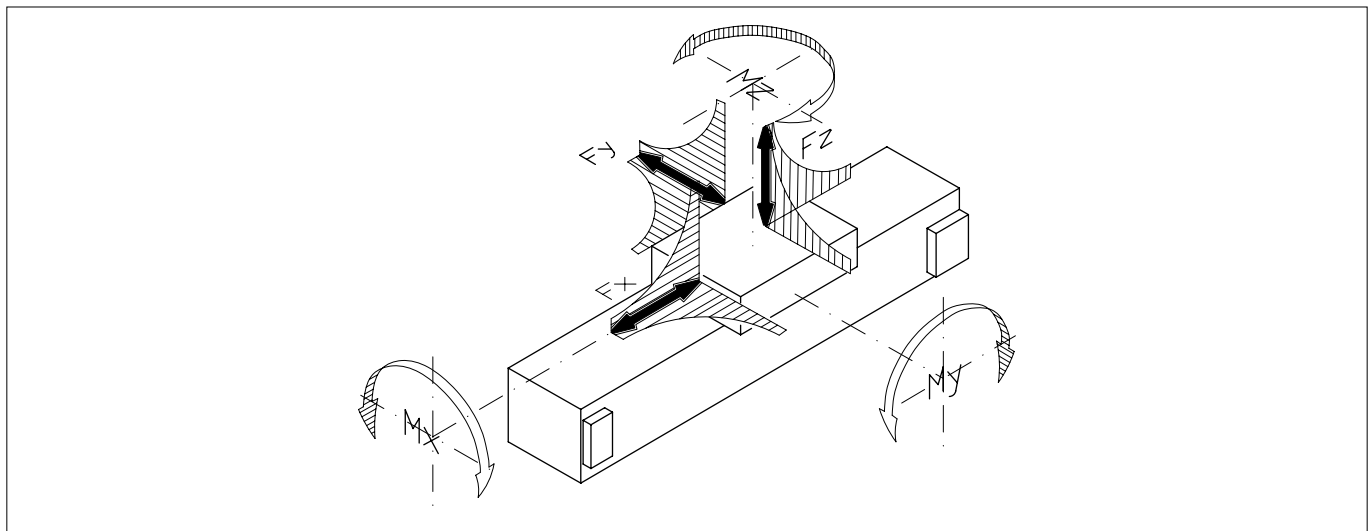

Type: **S5**

Ø mm	Force ( $V_{max} \leq 0,35 \text{ m/s}$ )			F (load in N)			Moments		
	Fx (N) 6 bar	Fy (N) 6 bar	Fz (N) 6 bar	at 0,75 m/s	at 1 m/s	at 1,5 m/s	Mx (Nm) Fy/Fz	My (Nm) Fx/Fz	Mz (Nm) Fx/Fy
18	140	150	150	50	30	12	1,8	1,8	1,8
25	270	250	250	100	60	30	4	4	4
32	440	450	450	250	135	65	10	10	10
40	680	600	600	480	280	140	16	16	16
50	1060	900	900	800	480	220	30	30	30
63	1680	1100	1100	1500	950	400	45	45	45

# Rodless Cylinders

Bores from 18 to 63 mm

## Loads and moments

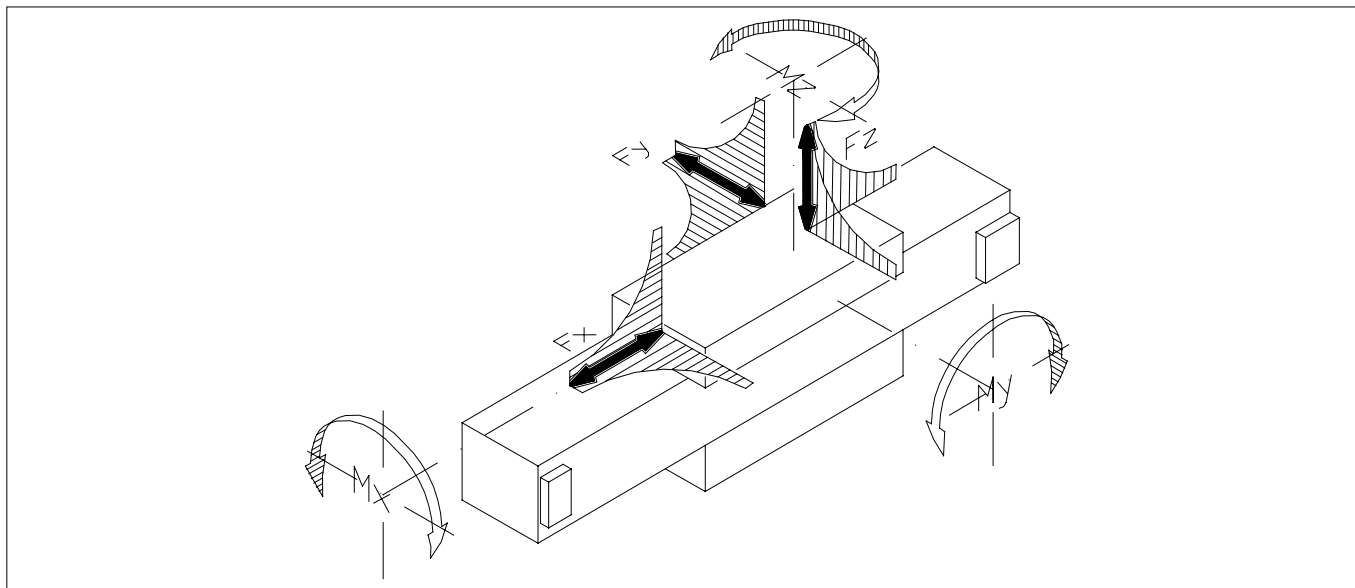

Type: **S6**

Ø mm	Force ( $V_{max} \leq 0,35 \text{ m/s}$ )			F (load in N)			Moments		
	Fx (N) 6 bar	Fy (N) 6 bar	Fz (N) 6 bar	at 0,75 m/s	at 1 m/s	at 1,5 m/s	Mx (Nm) Fy/Fz	My (Nm) Fx/Fz	Mz (Nm) Fx/Fy
18	140	550	550	150	80	20	5,2	9	9
25	270	1200	1200	420	210	80	15	30	30
32	440	1800	1800	750	400	170	37	67	67
40	680	2400	2400	1500	750	300	60	110	110
50	1060	3200	3200	2200	1150	460	120	220	220
63	1680	4200	4200	3700	1900	740	170	370	370

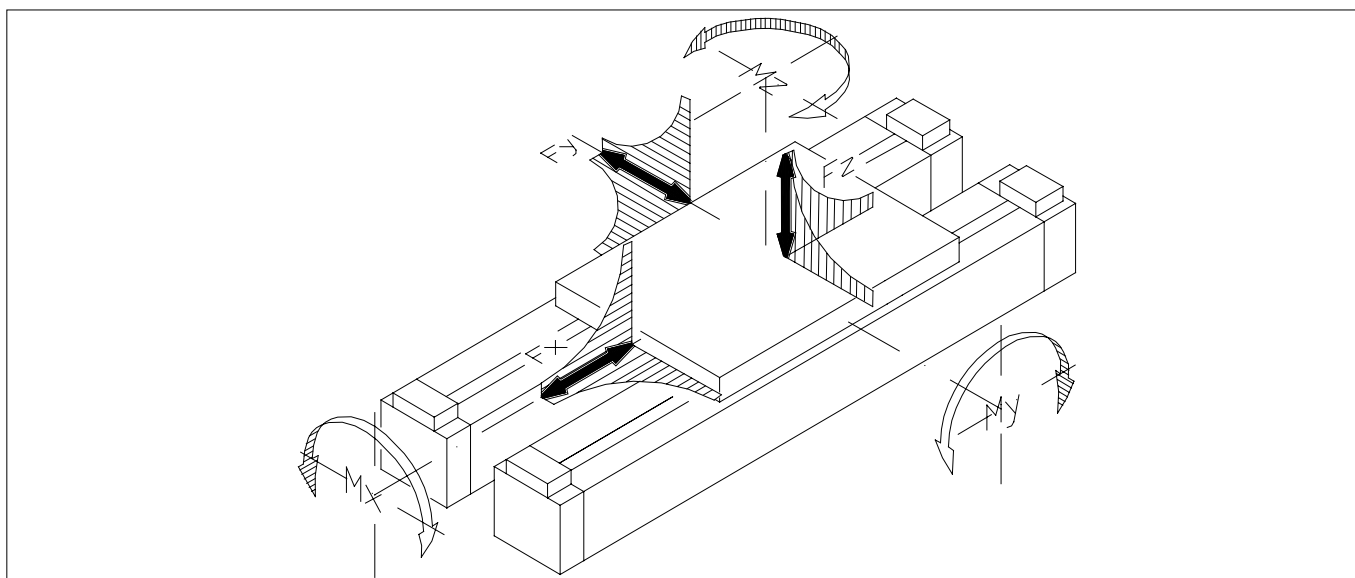

Type: **S4**

Ø mm	Force ( $V_{max} \leq 0,35 \text{ m/s}$ )			F (load in N)			Moments		
	Fx (N) 6 bar	Fy (N) 6 bar	Fz (N) 6 bar	at 0,75 m/s	at 1 m/s	at 1,5 m/s	Mx (Nm) Fy/Fz	My (Nm) Fx/Fz	Mz (Nm) Fx/Fy
32	880	360	1220	540	300	130	29	52	52
40	1360	540	1750	1090	620	280	55	88	88
50	2120	750	2500	1760	1000	450	90	155	155
63	3360	1000	3300	2900	1660	720	148	260	260

Foot type: **P**

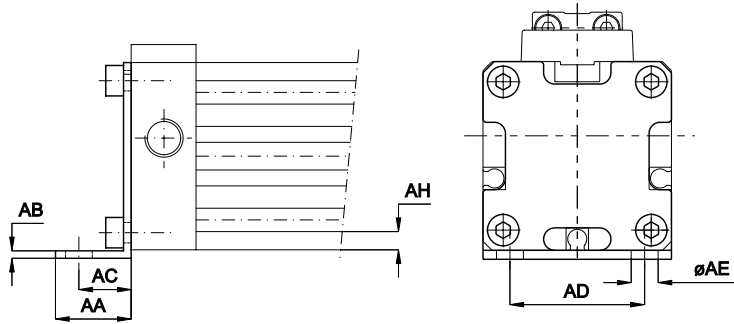

The feet can be mounted on the cylinder in all the 4 possible positions.  
The kit includes 2 feet and 8 bolts. Material: Anodised aluminium.

Code	Item	Ø mm	AA	AB	AC	AD	AE	AH
559010	P18S	18	15	2	10	20	6	2
559011	P25S	25	18	2	12,5	30	6	2
559012	P32S	32	20	2,5	13,5	40	7	3
559013	P40S	40	30	3	17,5	50	9	3,5
559014	P50S	50	28	3	20	60	9	3
559015	P63S	63	30	3	21	75	11	4,5

Mid support type: **SI**

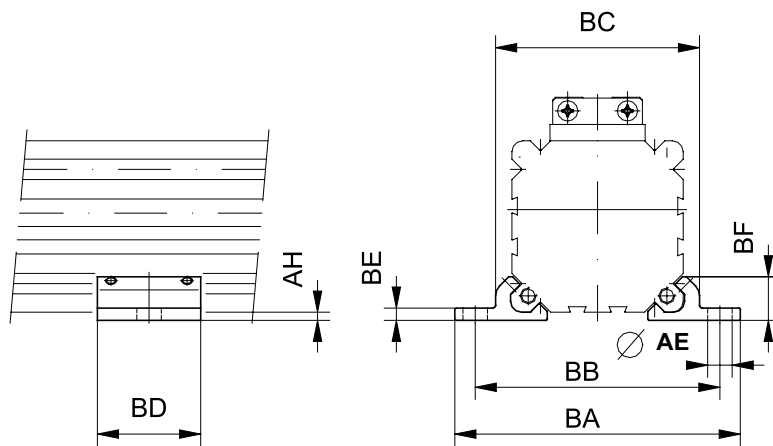

The mid support must be used in case of deflection of the cylinder (see page 1.26.40).

The mid support can be used instead of the foot. It is advisable to install it at the end of the cylinder and to secure it against any sideways drift of the cylinder by means of 2 bolts with washers that are screwed in at the front.

The kit includes 2 mid supports and 8 bolts. Material: Anodised aluminium.

Code	Item	Ø mm	AE Ø	AH	BA	BB	BC	BD	BE	BF
559020	SI18S	18	6	2	56	46	36,5	23	2,5	8,25
559021	SI25S	25	6	2	70	60	50	28	3,5	11
559022	SI32S	32	7	3	85	73	61,5	33	4	13,8
559023	SI40S	40	9	3	105	90	75	38	4,5	16
559024	SI50S	50	9	3	122	106	91	43	5	19
559025	SI63S	63	11	4,5	144	125	107	48	6	22

Maximum admissible deflections

Fz at deflection of 0,5 mm.

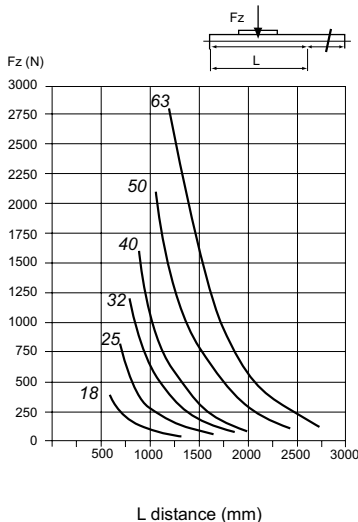

Fz at deflection of 1 mm.

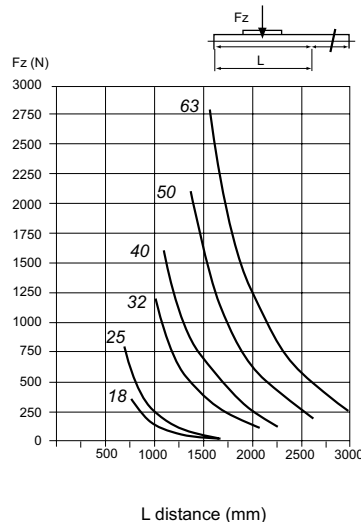

With cylinders of long strokes or heavy loads, you should pay attention to the tube deflection. One or more mid supports can be used according to the amount of deflection.

Example:

When applying a force Fz of 500 N a cylinder 25 mm should deflect by a maximum of 0,5 mm and be no longer than 750 mm as according to the diagram. Should you exceed 750 mm use one or more mid supports (see page 1.26.28).

# Rodless Cylinders

## Bores from 18 to 63 mm

### Mountings

Light flexible coupling type: **CL**

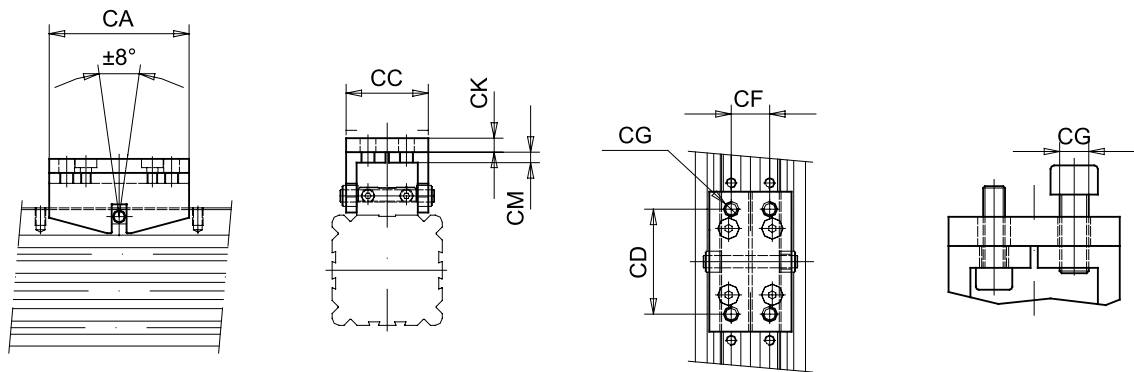

The light flexible coupling can be mounted where a guide must be connected to a rodless cylinder. The light flexible coupling transfers the action power to the guiding element without any tension. The kit includes 1 flexible coupling, 1 pin, 1 seeger, 2 distancers. Material: Anodised aluminium.

Code	Item	Ø mm	CA	CC	CD	CF	CG	CK	CM
559038	CL18S	18	50	25,5	30	9	M5	4	4
559037	CL25S	25	60	30	40	14	M5	4	4
559032	CL32S	32	70	37	50	16	M6	6	6
559033	CL40S	40	80	47	60	22	M8	8	8
559034	CL50S	50	90	56	70	30	M8	8	8
559035	CL63S	63	100	73	80	40	M10	8	8

Heavy flexible coupling type: **C**

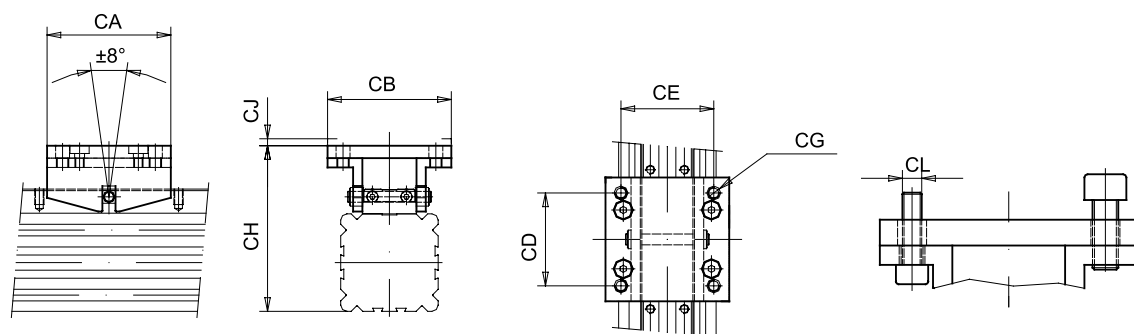

The heavy flexible coupling works as the light ones but can be used with higher forces. The kit includes 1 flexible coupling, 1 pin, 1 seeger, 2 distancers. Material: Anodised aluminium.

Code	Item	Ø mm	CA	CB	CD	CE	CG	CH	CJ	CL
559001	C18S	18	50	41,5	30	34	M5	54	2,5	M4
559002	C25S	25	60	50	40	38	M5	70	3	M4
559003	C32S	32	70	60	50	48	M6	86	3,5	M5
559004	C40S	40	80	80	60	60	M8	107	4,5	M6
559005	C50S	50	90	95	70	70	M8	123	4,5	M6
559006	C63S	63	100	120	80	80	M10	145,5	5	M8

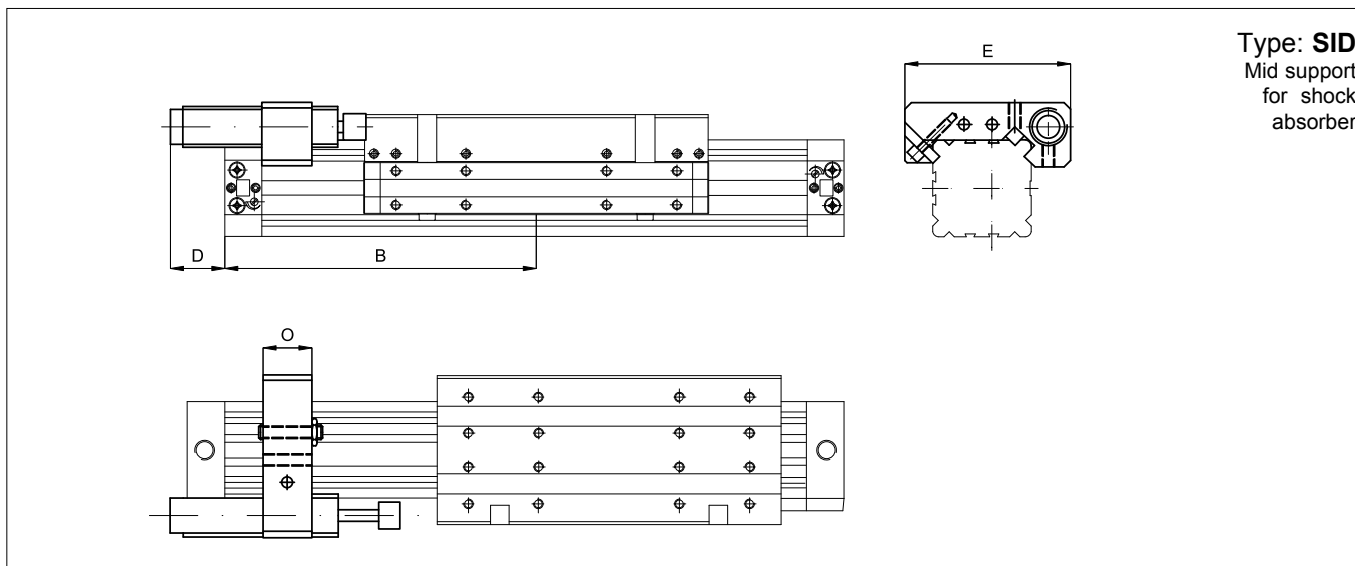

Type: **SID**  
Mid support  
for shock  
absorber

Code	Item	Ø mm	B		AH	D max	E	M	O
			S <sub>3</sub>	S <sub>5</sub>					
559060	SID18S	18	113	90.5	2	25	57	M10x1	15
559061	SID25S	25	117,5	85	2	40	72	M14x1,5	20
559062	SID32S	32	135,5	90	3	30	84	M14x1,5	20
559063	SID40S	40	165	110	3	50	105	M25x1,5	30
559064	SID50S	50	195	140	3	65	126	M25x1,5	30
559065	SID63S	63	250	160	4,5	75	140	M25x1,5	40

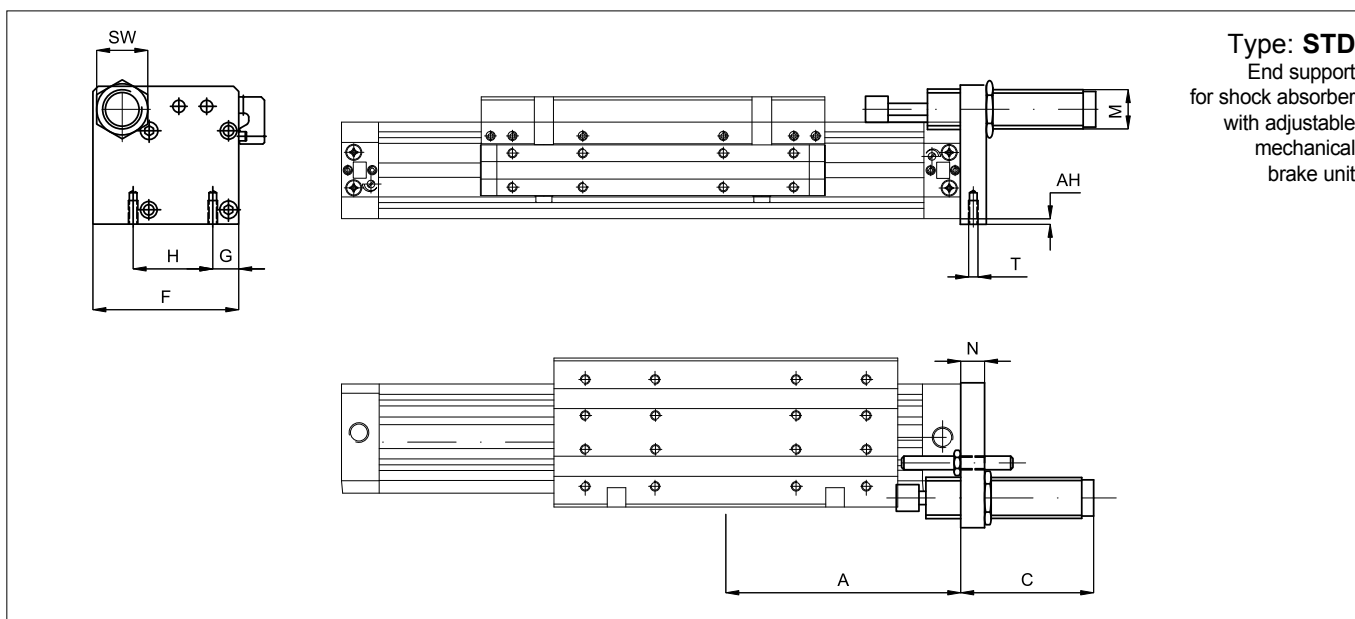

Type: **STD**  
End support  
for shock absorber  
with adjustable  
mechanical  
brake unit

Code	Item	Ø mm	A		AH	C	F	G	H	N	SW	T
			S <sub>3</sub>	S <sub>5</sub>								
559070	STD18S	18	80	57,5	2	32	43.5	8	23.5	8	13	M3x10
559071	STD25S	25	100	67,5	2	37	57	12,5	33	10	17	M4x10
559072	STD32S	32	120	77,5	3	70	70	14,5	41	12	17	M5x12
559073	STD40S	40	150	95	3	65	93	16	51	15	32	M6x15
559074	STD50S	50	180	105	3	80	102	22,5	63	15	32	M8x20
559075	STD63S	63	215	125	4,5	80	118.5	20	78	15	32	M8x20

Magnetic switch fixing

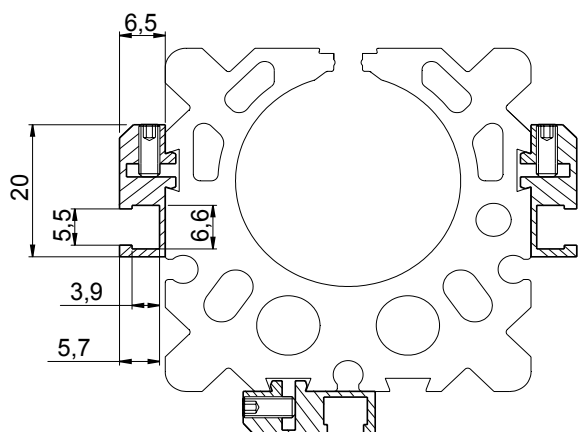

For magnetic switches type ASV  
(see page 1.110.1)  
use bracket AS55 (cod. 559050).

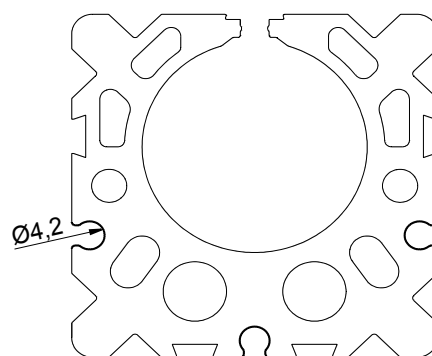

For magnetic switches type ASC  
(see page 1.110.2)  
direct mounting in the slot made in the tube.

