

Standard executions			
Version	Profile Tube	Symbol	Type
STANDARD MAGNETIC			AMA
			AMT

For the magnetic reed switches type ASV and ASC
see from page 1.110.1.

For coupling cylinders/reed switches/brackets
see table on page 1.120.5.

For mounting accessories see from page 1.97.1.

For rod accessories see from page 1.85.1.

For dimensions of the cylinder with piston rod brake
see page 1.75.15.



New series of cylinders conforming to ISO 15552 standards. These can be supplied with two different shapes of the barrel: AMA type with grooves allowing to use the flush-mounted magnetic switch and the AMT type round with tie-rods. Two different shapes of switches can be applied on opposite sides of AMA tube, to interchange with most competitors. The main features of this cylinder are the "clean" modern design and the attention to details. A particular attention was put to the end caps, thus eliminating contamination traps.



On request, they can be supplied according to 94/9/EC - **ATEX**

Options	Suffix
Through rod	P
Rod in stainless steel AISI 304	K
Extended rod in hardened and chrome plated steel for the application of the static piston rod brake	B
Extended rod in hardened and chrome plated steel for the application of the dynamic piston rod brake	B1
Seals FKM max 150°C (scraper ring only = V1)	V
Low temperature seals -40°C ÷ +80°C	BT
Tandem forward movement piston rods coupled together	TA1
Tandem forward movement piston rods independent	TA2
Tandem back to back	TA3
Tandem front to front	TA4
Extended rod (indicate the requested WH dimension in mm. E.g.: WH -100).	WH-...
Without adjustable cushionings	D
Adjustable rear cushioning only	D1
Adjustable front cushioning only	D2
Special male thread (indicate the requested thread. E.g. : R-M 10x1,5). The dimension AM of the special thread will be the same as the standard. The cylinder will be supplied without rod nut.	R-M...
Female thread	F
With bellows for protection of the rod (in this case the dimension WH will be extended according the stroke of the cylinder)	Z
Low friction (type AMT only from Ø32 to Ø100)	L
Piston rod scraping ring in nitrile rubber NBR	H
Brass rod scraper	Y
Special on request	/S

The options can be combined (when this is possible).

The suffix of the options are to be added to the model number of the standard product, as shown in the following table.

How to order: 63 / 100 AMAKVR-M12x1,25

63	/	100	AMA	K	V	R-M12X1,25
Bore	/	Stroke	Type	Option	Option	Option

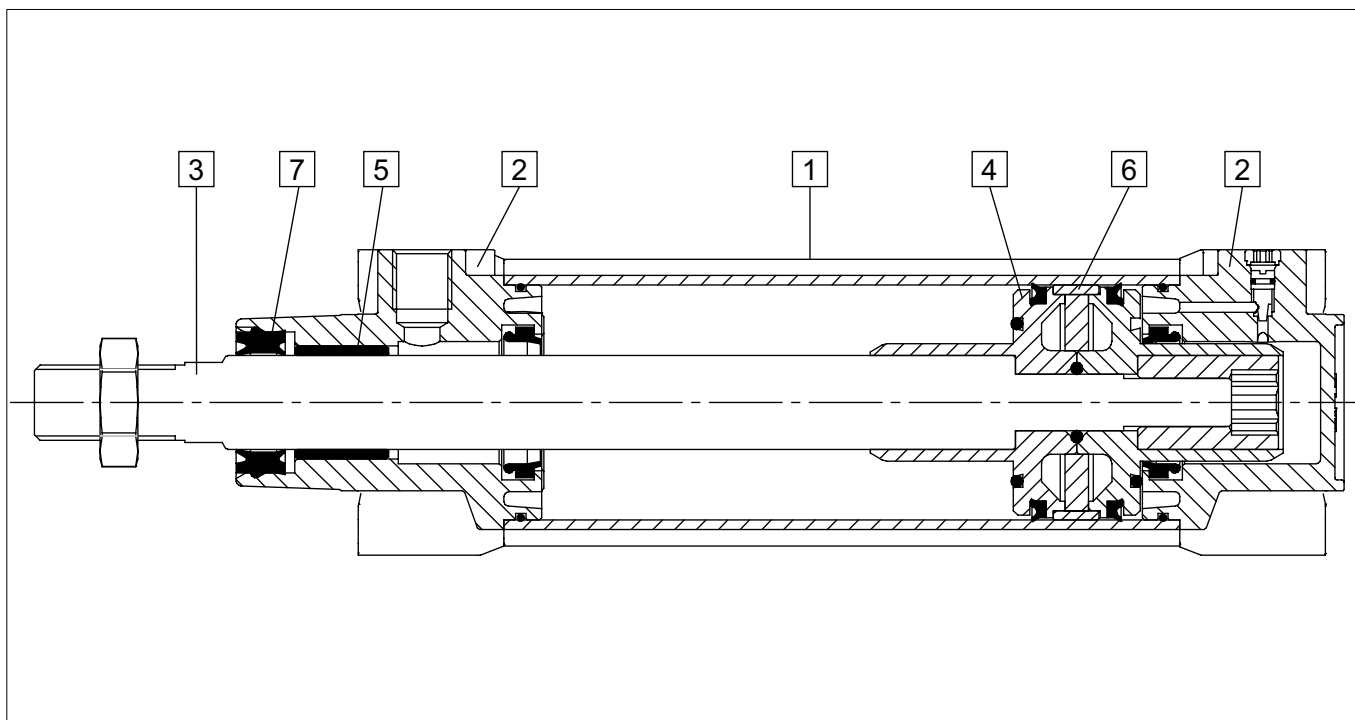

Materials (standard types)	
1 Tube	Anodised aluminium
2 Heads	Die-cast painted aluminium
3 Rod	Chrome-plated steel C45
4 Piston	Die-cast aluminium
5 Bushing	Self-lubricating sintered bronze
6 Guide ring	Natural Delrin
7 Rod seals	Polyurethane
Other seals	Nitrile rubber NBR/polyurethane

Technical data								
Bore (mm)	32	40	50	63	80	100	125	
Fluid	Compressed filtered air with or without lubrication. Lubrication, if started, must be continued.							
Pressure	1 ÷ 10 bar							
Temperature range	-20 °C ÷ +80 °C							
Stroke	from 10 mm to 2500 mm							
Cushion lenght	20	22	25	25	35	35	35	
Ports	1/8"	1/4"		3/8"		1/2"		
Rod thread	M10 x 1,25	M12 x 1,25	M16 x 1,5		M20 x 1,5		M27 x 2	
Weight	Stroke zero (g)	470	690	1145	1483	2381	3181	5284
	Additional 10 mm stroke (g)	21	29	44	47	69	80	119

Type: **AMA**

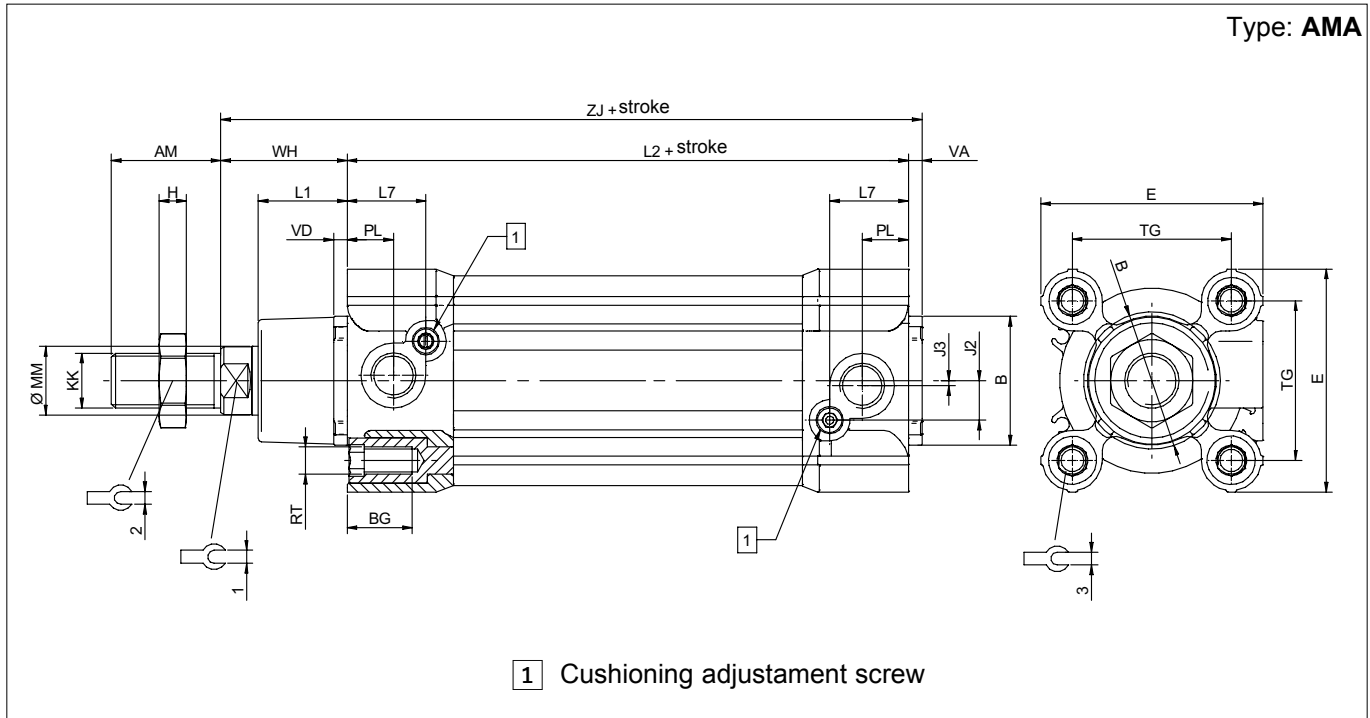

Ø (mm)	AM	B Ø d11	BG	E	EE	J2	J3	KK	L1	L2	H
32	22	30	15	47	1/8"	7	3,5	M10x1,25	20	94	6
40	24	35	15	52	1/4"	7,5	4	M12x1,25	22	105	7
50	32	40	16	65	1/4"	11,5	1,5	M16x1,5	26	106	8
63	32	45	15	75	3/8"	13,5	1	M16x1,5	25	121	8
80	40	45	17	95	3/8"	13	1	M20x1,5	32	128	9
100	40	55	17	115	1/2"	15	6	M20x1,5	38	138	9
125	54	60	21	140	1/2"	17	8	M27x2	40	160	12

Ø (mm)	L7	MM Ø f7	PL	RT	TG	VA	VD	WH	ZJ	1	2	3
32	19,4	12	8,5	M6	32,5	4	4	26	124	10	17	6
40	23	16	10	M6	38	4	4	30	139	13	19	6
50	23	20	13,5	M8	46,5	4	4	37	147	17	24	8
63	23	20	15	M8	56,5	4	4	37	162	17	24	8
80	30	25	21	M10	72	4	4	46	178	22	30	10
100	30,5	25	24	M10	89	4	4	51	193	22	30	10
125	27,5	32	23	M12	110	5	5	65	230	27	41	12

Seals kits	
n. 1	Rod seal
n. 2	Cushioning seal
n. 2	Piston lip-seal
n. 1	Linear rubber ring for piston (damper)
n. 2	Tube O-ring
n. 1	Piston guiding ring
n. 2	O-ring for cushioning screw
n. 2	O-ring to seal two semi-pistons

How to order: 63 / SG / AM

63	/	SG	/	AM
Bore	/	Seal kit	/	Type

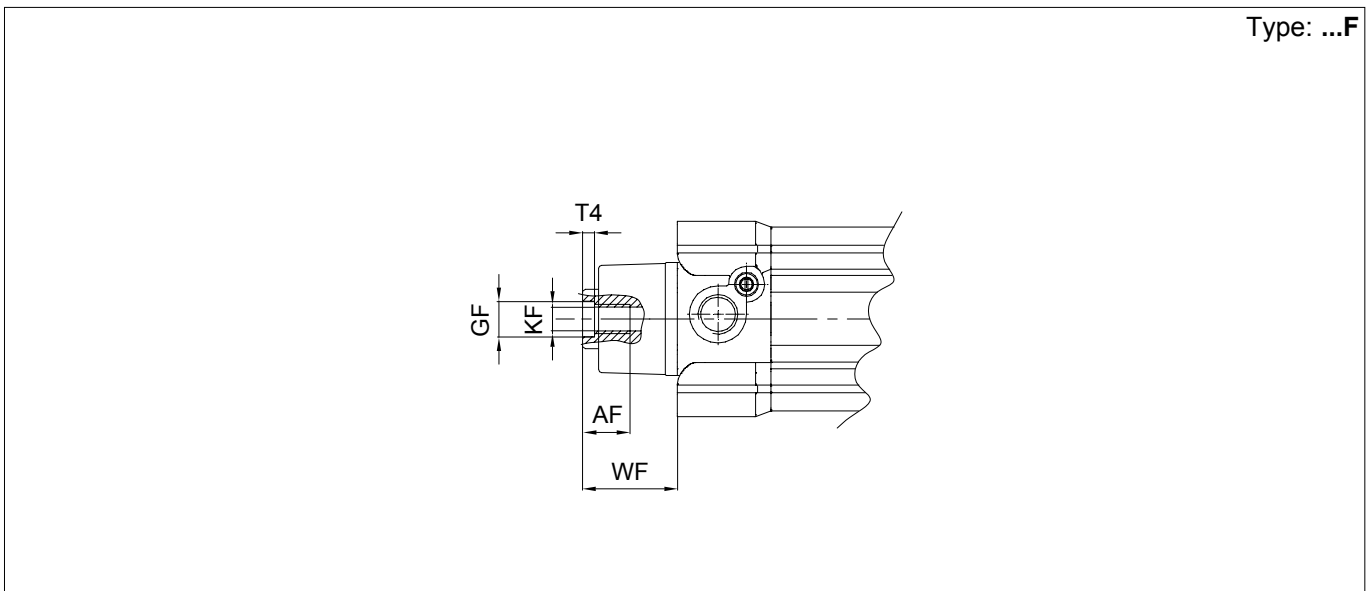
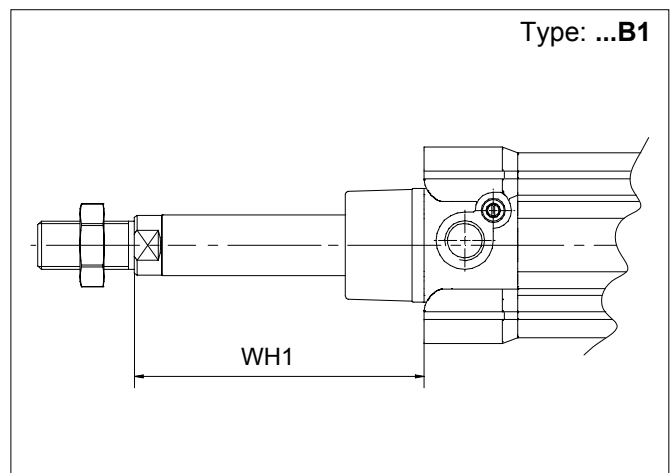
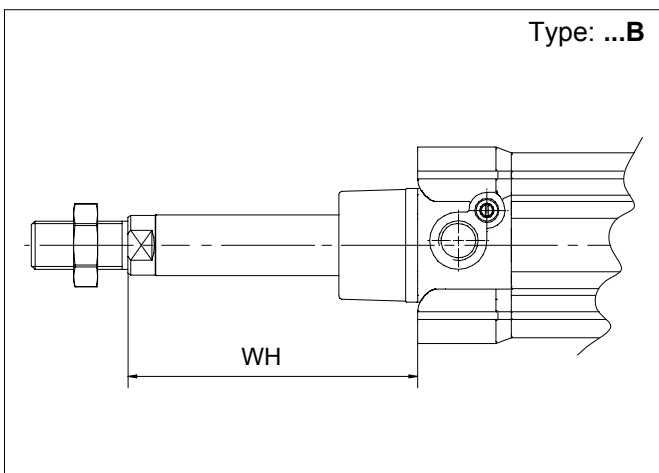
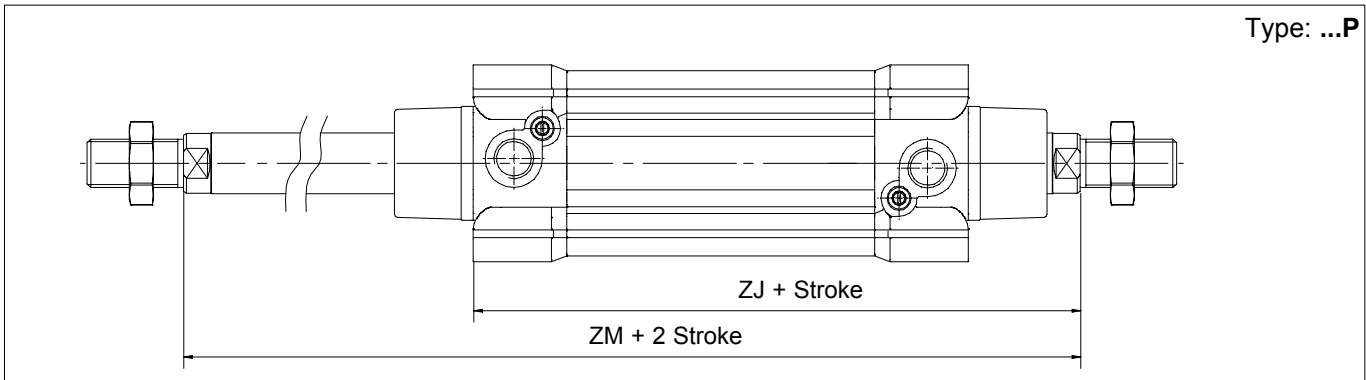

Ø mm	AF	GF	KF	T4	WF	WH	WH1	ZJ	ZM
32	12	8	M6	2,6	26	74	99	120	146
40	12	10	M8	3,3	30	85	106	135	165
50	16	12	M10	4,7	37	107	127	143	180
63	16	12	M10	4,7	37	107	129	158	195
80	20	14	M12	6,1	46	136	156	174	220
100	20	14	M12	6,1	51	143	181	189	240
125	32	18	M16	8	65	187	-	225	290

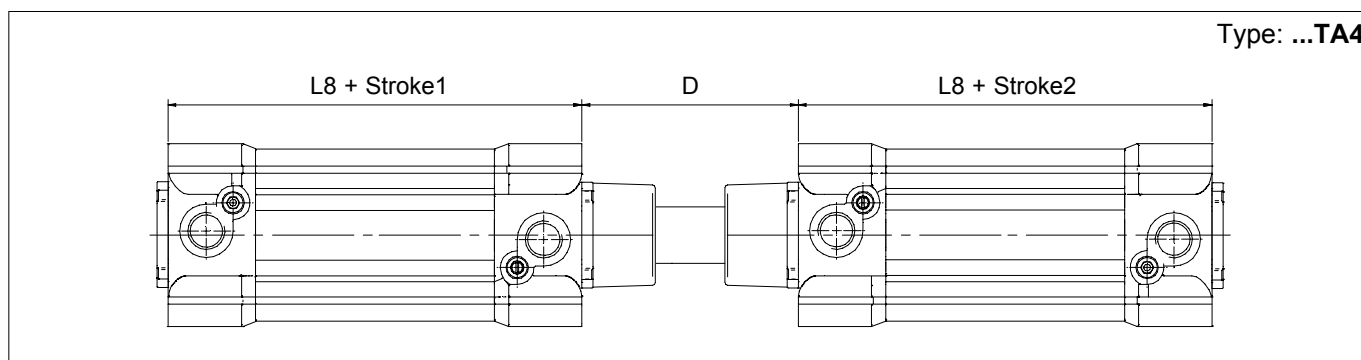
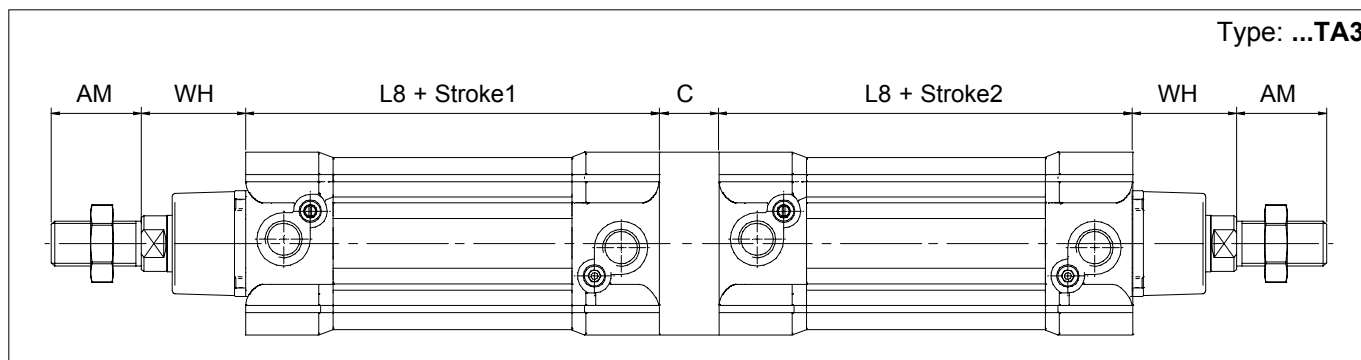
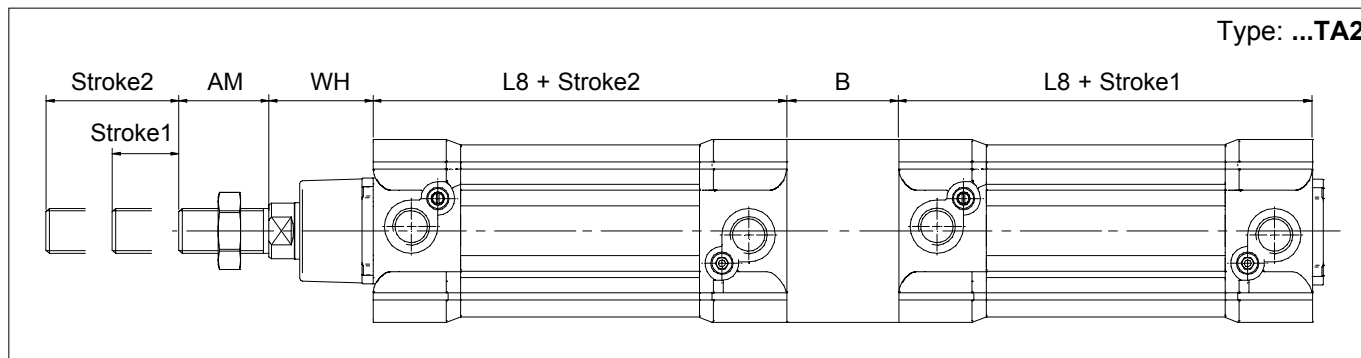
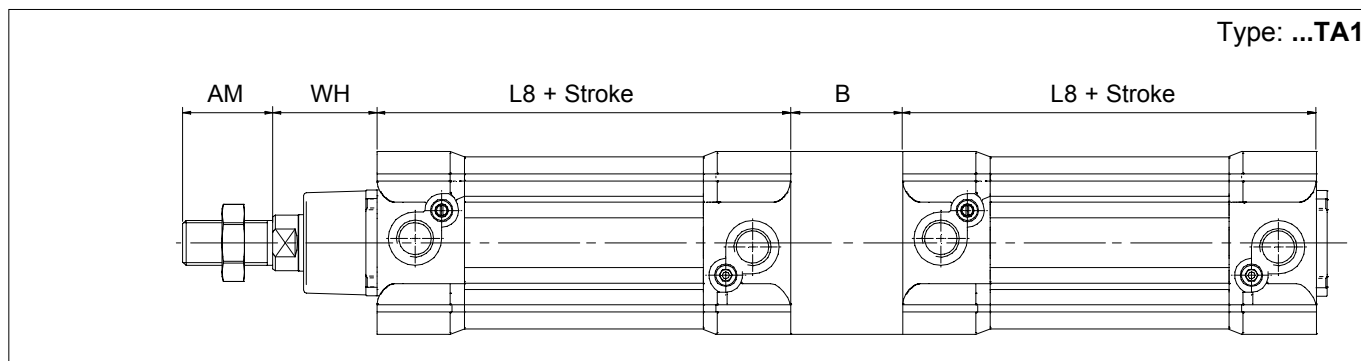

Ø mm	AM	B	C	D	L8	WH
32	22	40	12	48	94	26
40	24	44	12	54	105	30
50	32	52	16	69	106	37
63	32	50	16	69	121	37
80	40	64	20	86	128	46
100	40	76	20	91	138	51
125	54	80	35	120	160	65

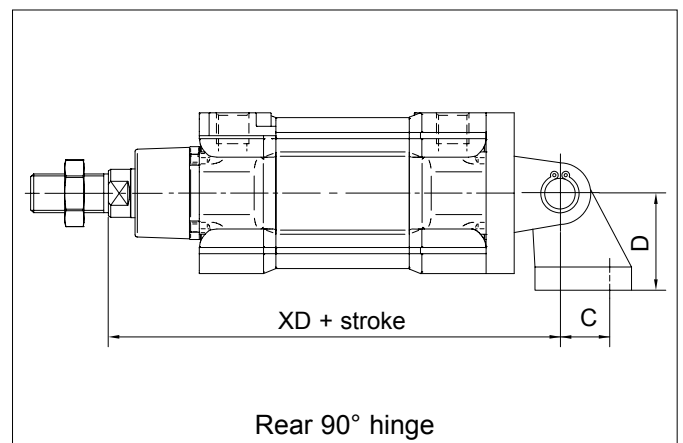
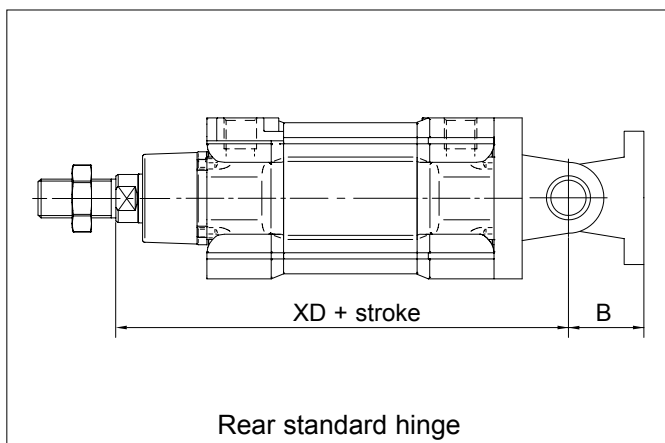
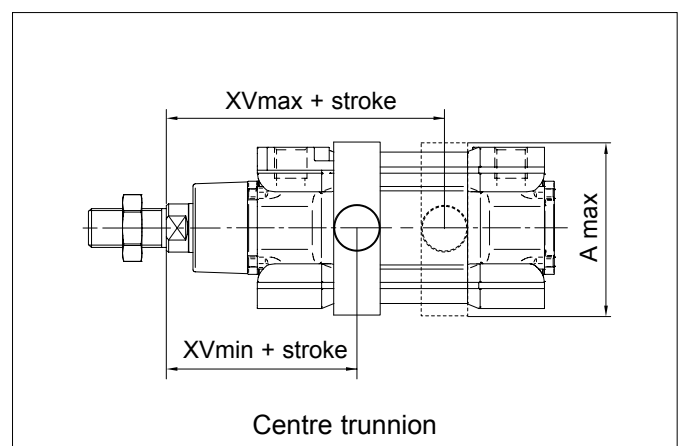
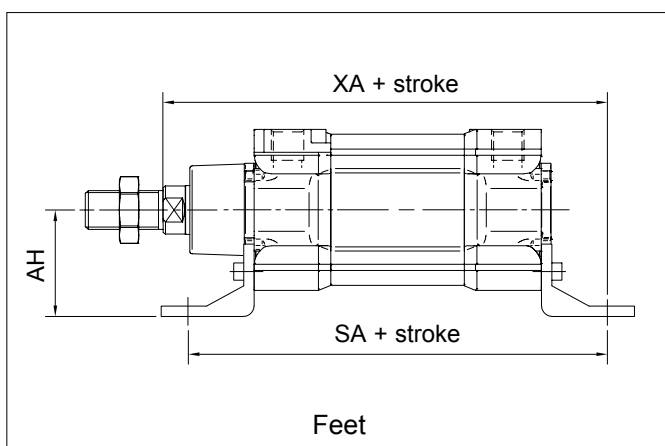
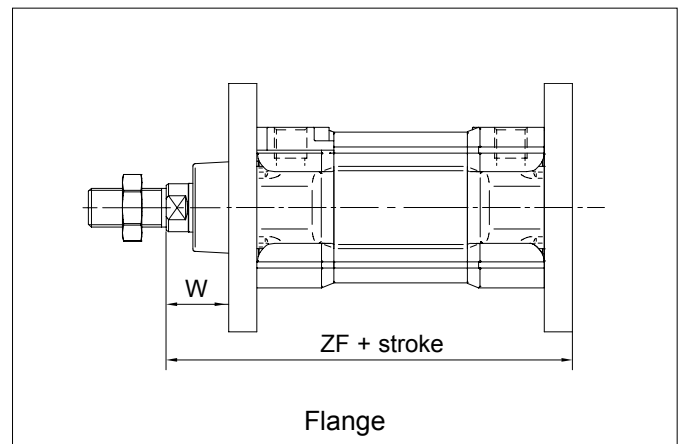
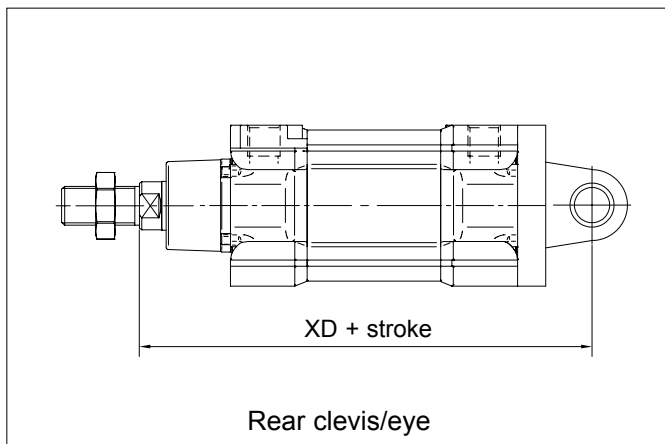

Ø mm	A max	AH	B	C	D	SA	W	XA	XD	XV min	XV max	ZF
32	70	32	22	21	32	142	16	144	142	60	86	130
40	78	36	25	24	36	161	20	163	160	69	96	145
50	91	45	27	33	45	170	25	175	170	78	102	155
63	94	50	32	37	50	185	25	190	190	82	113	170
80	130	63	36	47	63	210	30	215	210	97	123	190
100	145	71	41	55	71	220	35	230	230	107	133	205
125	170	90	50	70	90	250	45	270	275	126,5	163,5	245

For dimensions and codes of the accessories: see page 1.97.1